

DATE: October 30, 2014

BID #: WS 82-14

ADDENDUM NO. 2

TO THE CONTRACT DOCUMENTS:

METAL BUILDING

East County Repump Project
Okaloosa County Water and Sewer System
Okaloosa County, Florida

To All Document Holders:

The following changes, additions, and or deletions are hereby made a part of the Bidding Documents for the **East County Repump Project – Metal Building**, Bid # WS 82-14 as fully and completely as if the same were fully set forth therein:

CONTRACT DOCUMENTS

QUESTIONS

Q: Specification for the foam plastic board insulation to go in the wall cavities and at roof panels per section 07210, then the metal bldg. section 13120 calls for vinyl faced fiberglass insulation could you clarify if both are to be installed or which to omit.

A: Use Section 13120 Specification and Drawing Table, vinyl faced fiberglass.

Q: Do all doors need to be impact resistant rated?

A: Yes, door type 'A' has keynote '08.04' which indicates 'IMPACT GLAZING.'

Q: Specifications call for flashing and trim including downspouts to be 24 gauge. 29 gauge is more common and accessible, especially on downspouts, will 29 gauge be acceptable?

A: Provide as currently specified, 24 gauge.

Q: What is "Serviceability Load" for the building? Please clarify the serviceability wind speed for this project.

A: Serviceability (drift, deflection, etc.) forces should be determined based on the Ultimate wind speed pressures multiplied by 0.6.

Q: Verify that only the partition wall (WT1) is to get plywood on it. All other walls will be exposed structure.

A: Confirmed

Q: In Division 1, General Requirements 01324, 1.04 B

Requires a site-specific Safety Plan for approval by the County. Will this plan cover only the work by the successful bidder, or all work done by the County and any of their subcontractors? Will a full time safety officer be required to be on site and monitor all workers on site, even if the successful bidder or any of their subcontractors are not on site?

A: Metal Building Contractor and associated sub-contractors shall be responsible for providing a safety plan to Okaloosa County to cover all work performed under their contracted scope. The Metal Building Contractor shall provide its own Safety officer under this Contract if needed.

Q: In Section 01500 Temporary Facilities and Controls, 1.3 Use Charges A, B, & C. Contractor to pay for all utilities including the owner's use. If this is the case can we put an allowance in the bid to cover the County's expense?

A: Okaloosa County Water & Sewer will be acting as the Primary Site Contractor for the Project and will be responsible for these expenses. Do not include any additional cost in your proposal for these temporary utilities.

Q: In Section 01500 Temporary Facilities and Controls, Part 2, Products, 2.3 Project Sign Will the Contractor be responsible to provide a Project Sign and if it is required will a detail be provided?

A: Okaloosa County Water & Sewer will be acting as the Primary Site Contractor for the Project and will be responsible for these requirements.

Q: Are the 4" concrete slabs outside the walk doors and the 6" drive slab adjacent to the roll-up door to be included in the contractor's scope?

A: YES, please include in your cost proposal

Q: Section 01500 – Temporary Controls requires the Contractor to provide an erosion/sediment control plan for the site. Because Contractor will only be constructing the metal building, will this be required?

A: Okaloosa County Water & Sewer will be acting as the Primary Site Contractor for the Project and will be responsible for these requirements.

Q: Will the County's electrical permit be a "stand alone" permit, or will it be under the General Contractor's electrical permit?

A: Stand Alone, Okaloosa County will obtain it's on electrical permit for their performed activities.

Q: Can the bridge crane rail beams be supported by the building's columns?

A: Yes. Preferred

Q: Clarify minimum height requirement from finish floor elevation to hook of bridge crane when fully retracted.

A: 8'-0"

Q: Will pdf format files be acceptable for project documentation?

A: Yes

Q: Will a copy of the geotechnical report be made available prior to the bid opening:

A: Please incorporate the following information into your cost proposal:

- No groundwater @ 15' below finished grade elevation
- A design bearing pressure of 1500 psf shall be utilized. Building sub-base footprint shall be compacted by Okaloosa County to 98 percent modified, vibratory roller method.
- Final geotechnical report will be posted to Contract Documents Folder (www.tcgeng.com/documents) on 11/01/2014.

TECHNICAL SPECIFICATIONS

00300 – Bid Proposal

- 1) FORMS – Bidders' Acknowledgement:
 - a. **ADD** –The attached form titled “REQUEST FOR BID (RFB) & BIDDER’S ACKNOWLEDGEMENT” shall be completed, signed, and returned as part of bidder’s proposal. No Bid will be accepted without this form, signed by an authorized agent of the bidder.”

00500 – Standard Agreement

- 1) Article 4 – Contract Time:
 - a. **REPLACE** –00500.4.02.Days to Achieve Substantial Completion: Paragraph A in its entirety with the following language: “The Work will be substantially completed within 120 days from the date when the Contract Time commences to run as provided in paragraph 2.03 of the General Conditions, and completed and ready for final payment in accordance with paragraph 14.07.B of the General Conditions within 180 days from the date when the Contract Time commences to run. Contract time shall include a 10 working day submittal review and period by the Owner/Engineer”

01310 – Project Management and Coordination

- 1) Part 3- Execution:

DELETE – 01310.3.1.A.1 in its entirety

13120 – Metal Building Systems

- 2) Part 2- Products:
 - a. **ADD** – 13120.2.2.B.2 (f.): “For incorporation of the overhead bridge crane the maximum vertical deflection of the girder beam produced by the weight of the hoist, trolley and the rated load shall not exceed 1/888 of the span. Vertical inertia forces shall not be considered in determining deflection. In addition, if camber of the girder is desired the camber shall be an amount equal to the dead load deflection plus one-half of the live load deflection. (These requirements are necessary for compliance with CMAA Specification 70-2000.) The proposed camber shall be approved in writing by the Crane supplier prior to fabrication of the metal building. The girder shall be permanently and clearly marked to identify the top side of the beam to ensure that the cambered side is installed “up.”
 - b. **CHANGE** –13120.2.2. (H): “Reference Structural Drawing (S1) for wind speed, risk category & wind exposure category requirements.”

Plan Drawings

- 1) Structural Drawings:
 - a. **REPLACE** – Plan Drawings S1.0 General Notes in its entirety with the attached revised Drawing S1.0.
- 2) General Drawings:
 - a. **CLARIFICATION** – Plan drawing G1.1:

- i. General Note 2. The reference to the Contractor for site clearing activities pertains to the Site/Civil Contractor (Okaloosa County)
- 3) Mechanical Drawings:
 - a. **CLARIFICATION**- Plan Drawing M1.0- Concrete Pump Pad dimensional requirements.
 - b.
- 4) Structural Drawings:
 - a. **REPLACE** – Plan Drawings M1.2 Mechanical Piping Plan in its entirety with the attached revised Drawing M1.2

All Plan Holders shall acknowledge receipt and acceptance of Addendum No. 2 in the Proposal or by submitting the executed Addendum to Constantine Engineering prior to Proposal Submittal.

Constantine Engineering

//Signed//
Joey G. Crews

Receipt acknowledged and conditions agreed to this

_____ day of _____, 2014

BIDDER

By

END OF ADDENDUM NO. 2



REQUEST FOR BID (RFB) & BIDDER'S ACKNOWLEDGEMENT

RFB TITLE:

Metal Bldg. East County Repump Project

RFB NUMBER:

WS 82-14

RFB OPENING DATE & TIME:

November 5, 2014 3:00 P.M. CT

MANDATORY PRE-BID MEETING:

October 16, 2014 10:00 A.M. CT

Location of Pre-Bid: Okaloosa County Water & Sewer Building, 1804 Lewis Turner Blvd., Large Conference Room, Fort Walton Beach, FL 32547

NOTE: BIDS RECEIVED AFTER THE BID OPENING DATE & TIME WILL NOT BE CONSIDERED.

Okaloosa County, Florida solicits your company to submit a bid on the above referenced goods or services. All terms, specifications and conditions set forth in this RFB are incorporated into your response. A bid will not be accepted unless all conditions have been met. All bids must have an authorized signature in the space provided below. All bids must be sealed and received by the Okaloosa County Clerk of Court by the "RFB Opening Date & Time" referenced above. The official clock for the purpose of receiving bids is located in the Clerk of Court, Brackin Building Conference & Training Room, #305 located at 302 N. Wilson St, Crestview, FL 32536. All envelopes containing sealed bids must reference the "RFB Title", "RFB Number" and the "RFB Opening Date & Time". Okaloosa County is not responsible for lost or late delivery of bids by the U.S. Postal Service or other delivery services used by the respondent. Neither faxed nor electronically submitted bids will be accepted. Bids may not be withdrawn for a period of sixty (60) days after the bid opening unless otherwise specified. **A mandatory pre-bid conference is scheduled for 10:00 am local time on, October 16, 2014 in the 3rd Floor Large Conference Room of the Okaloosa County Water and Sewer Administrative Building, located at 1804 Lewis Turner Blvd, Fort Walton Beach, Florida. You must attend this pre-bid conference in order to submit a bid. To obtain electronic copies of the bid documents: A hardcopy of bid provisions, bid forms, drawings and specifications may be reviewed at the following: Okaloosa County Water & Sewer Office located at 1804 Lewis Turner Boulevard, Suite 300, Fort Walton Beach, Florida, 32547. Okaloosa County Purchasing Department, located at 602-C North Pearl Street, Crestview, FL 32536. Electronic copies may be obtained from CONSTANTINE ENGINEERING, INC., under the project name at the following web address: <http://www.tcgeng.com/Documents/>.**

BIDDER ACKNOWLEDGEMENT FORM BELOW MUST BE COMPLETED, SIGNED, AND RETURNED AS PART OF YOUR BID. BIDS WILL NOT BE ACCEPTED WITHOUT THIS FORM, SIGNED BY AN AUTHORIZED AGENT OF THE BIDDER.

COMPANY NAME _____

MAILING ADDRESS _____

CITY, STATE, ZIP _____

FEDERAL EMPLOYER'S IDENTIFICATION NUMBER (FEIN): _____

TELEPHONE NUMBER: _____ EXT: _____ FAX: _____

EMAIL: _____

I CERTIFY THAT THIS BID IS MADE WITHOUT PRIOR UNDERSTANDING, AGREEMENT, OR CONNECTION WITH ANY OTHER BIDDER SUBMITTING A BID FOR THE SAME MATERIALS, SUPPLIES, EQUIPMENT OR SERVICES, AND IS IN ALL RESPECTS FAIR AND WITHOUT COLLUSION OR FRAUD. I AGREE TO ABIDE TO ALL TERMS AND CONDITIONS OF THIS BID AND CERTIFY THAT I AM AUTHORIZED TO SIGN THIS BID FOR THE BIDDER.

AUTHORIZED SIGNATURE: _____ TYPED OR PRINTED NAME _____

TITLE: _____ DATE _____

1.00 GENERAL NOTES

- 1.01 ALL CONSTRUCTION SHALL CONFORM TO THE FLORIDA BUILDING CODE, LATEST EDITION.
- 1.02 WIND LOADS: THE STRUCTURE HAS BEEN DESIGNED TO CONFORM TO THE WIND PROVISIONS OF ASCE 7-10. SEE WIND PRESSURE DIAGRAM & CHART FOR DESIGN ASSUMPTIONS.
- 1.03 DESIGN GRAVITY LOADS ARE AS FOLLOWS:
 - A. SUPERIMPOSED DEAD LOADS:
 - 1. MECHANICAL, ELECTRICAL, PLUMBING: 5 PSF
 - 2. CEILINGS AND INSULATION: 5 PSF
 - B. LIVE LOADS: (MAY BE REDUCED PER CODE)
 - 1. ROOFS: 20 PSF
 - 2. SLAB-ON-GRADE: 100 PSF
 - 3. INDUSTRIAL: 200 PSF
 - C. CRANE LOADS: (PINNED COLUMN TRANSFERRING VERTICAL LOAD ONLY)
 - 1. CRANE: 4,000 LBS (2 TON CRANE)
- 1.04 DRAWINGS SHOW TYPICAL AND CERTAIN SPECIFIC CONDITIONS ONLY. FOR DETAILS NOT SPECIFICALLY SHOWN, PROVIDE DETAILS SIMILAR TO THOSE SHOWN.
- 1.05 THE DESIGN, ADEQUACY, AND SAFETY OF ERECTION BRACING, SHORING, TEMPORARY SUPPORTS, ETC., ARE THE SOLE RESPONSIBILITY OF THE CONTRACTOR.
- 1.06 COORDINATE STRUCTURAL CONTRACT DOCUMENTS WITH ARCHITECTURAL, MECHANICAL, ELECTRICAL, PLUMBING AND CIVIL. NOTIFY STRUCTURAL ENGINEER OF ANY CONFLICT AND/OR OMISSION. CONTRACTOR SHALL MAKE NO DEVIATION FROM DESIGN DRAWINGS WITHOUT WRITTEN APPROVAL OF THE ARCHITECT. FOR ADDITIONAL OPENINGS NOT SHOWN ON THE STRUCTURAL DRAWINGS, SEE ARCHITECTURAL, MECHANICAL, AND PLUMBING DRAWINGS.
- 1.07 REVIEW OF SUBMITTALS AND/OR SHOP DRAWINGS BY THE STRUCTURAL ENGINEER DOES NOT RELIEVE THE CONTRACTOR OF THE RESPONSIBILITY TO REVIEW AND CHECK SHOP DRAWINGS BEFORE SUBMITTAL TO THE STRUCTURAL ENGINEER. THE CONTRACTOR REMAINS SOLELY RESPONSIBLE FOR ERRORS AND OMISSIONS ASSOCIATED WITH THE PREPARATION OF SHOP DRAWINGS AS THEY PERTAIN TO MEMBER SIZES, DETAILS, AND DIMENSIONS SPECIFIED IN THE CONTRACT DOCUMENTS. CONTRACTOR IS ALSO RESPONSIBLE FOR MEANS, METHODS, TECHNIQUES, SEQUENCES, AND PROCEDURES OF CONSTRUCTION.

- 2.00 FOUNDATIONS AND SLAB-ON-GRADE
 - 2.01 THE DESIGN OF FOUNDATIONS AND SLABS-ON-GRADE ARE BASED ON THE CRITERIA ESTABLISHED IN THE GEOTECHNICAL REPORT BY COMPANY NAME, CITY, STATE; FILE #NUMBER, DATED DATE. THE RECOMMENDATIONS OF THAT REPORT SHALL BE CONSIDERED AN INTEGRAL PART OF THE CONTRACT DOCUMENTS.
 - 2.02 SHALLOW FOUNDATIONS HAVE BEEN DESIGNED FOR AN ALLOWABLE SOIL BEARING PRESSURE OF 1,500 PSF.
 - 2.03 A QUALIFIED GEOTECHNICAL ENGINEER SHALL VERIFY CONDITION AND/OR ADEQUACY OF ALL SUBGRADES, FILLS AND BACKFILLS BEFORE PLACEMENT OF FOUNDATIONS, FOOTINGS, SLABS, WALLS, FILLS, BACKFILLS, ETC. SHOULD THE CONTRACTOR FIND UNDESIRABLE SOILS, HE SHALL STOP WORK AND IMMEDIATELY CONTACT THE ENGINEER OF RECORD. ALL FOOTINGS SHALL REST EITHER ON UNDISTURBED SOIL OR A MANUALLY OPERATED VIBRATORY SLED OR TAMPER SHOULD BE USED TO DENSIFY ANY SOILS IN THE BOTTOM OF THE FOOTING TRENCHES LOOSENED DURING THE EXCAVATION OPERATION.
 - 2.04 SIDES OF FOUNDATIONS SHALL BE FORMED UNLESS CONDITIONS PERMIT EARTH FORMING. FOUNDATIONS POURED AGAINST THE EARTH REQUIRE THE FOLLOWING PRECAUTIONS: SLOPE SIDES OF EXCAVATIONS AS APPROVED BY GEOTECHNICAL ENGINEER AND CLEAN UP SLOUGHING BEFORE AND DURING CONCRETE PLACEMENT.
 - 2.05 CONTRACTOR IS RESPONSIBLE FOR ADEQUATELY PROTECTING ALL EXCAVATION SLOPES.
 - 2.06 DO NOT STEP FOOTINGS.
 - 2.07 SLAB-ON-GRADE REQUIREMENTS:
 - A. UNLESS NOTED OTHERWISE, THE SLAB-ON-GRADE SHALL BE A MINIMUM OF 6 INCHES THICK, PLACED ON A COMPACTED SUBGRADE, AND REINFORCED WITH #3 BARS AT 12" ON CENTER, EACH WAY. PROVIDE POSITIVE SUPPORT 3" CLEAR FROM BOTTOM OF SLAB. LAP BARS 2'-0".
 - B. PLACE CONTROL OR CONSTRUCTION JOINTS AT LOCATIONS INDICATED BY "C.J." SAW CUT CONTROL JOINTS AS SOON AFTER POURING AS POSSIBLE WHEN CONCRETE WILL NOT RAVEL; 12 HRS. MAX. CURE CONCRETE IN ACCORDANCE WITH ACI 301. BEGIN CURING IMMEDIATELY AFTER POURING TO LIMIT CRACKING PRIOR TO SAW CUTTING CONTROL JOINTS.
 - C. SUBGRADE SHALL BE PREPARED AS RECOMMENDED IN THE GEOTECHNICAL REPORT. PROVIDE A COMPACTED CAPILLARY BARRIER OF 4" MINIMUM THICKNESS OF A COMPACTIBLE, EASY-TO TRIM, GRANULAR FILL THAT WILL REMAIN STABLE AND SUPPORT CONSTRUCTION TRAFFIC. THE TIRE OF A LOADED CONCRETE TRUCK MIXER SHOULD NOT PENETRATE THE SURFACE MORE THAN 1/2 IN. (13 MM) WHEN DRIVEN ACROSS THE BASE. CLEAN SAND WITH UNIFORM PARTICLE SIZE, SUCH AS CONCRETE SAND MEETING ASTM C33, WILL NOT BE ADEQUATE. A CLEAN, FINE-GRADED MATERIAL WITH AT LEAST 10 PERCENT TO 30 PERCENT OF PARTICLES PASSING A NO. 100 SIEVE BUT NOT CONTAMINATED WITH CLAY, SILT, OR ORGANIC MATERIAL IS RECOMMENDED. THE MATERIAL SHALL HAVE A UNIFORM DISTRIBUTION OF PARTICLE SIZES RANGING FROM NO. 4 THROUGH THE NO. 200 SIEVES. UNWASHED SIZE NO. 10 PER ASTM D 448 WORKS WELL. THE MATERIAL SHOULD HAVE SUFFICIENT MOISTURE CONTENT TO BE COMPACTIBLE. FDOT 2D (821) 1/4" MOD IS AN ACCEPTABLE PRODUCT.
 - D. VAPOR RETARDER SHALL CONFORM TO ASTM E1745, CLASS A, B, & C AND A MINIMUM OF 10 MIL THICKNESS. VAPOR RETARDER SHOULD BE PLACED OVER THE CAPILLARY BARRIER OVER A THIN LAYER OF APPROXIMATELY 1/2 IN. OF FINE-GRADED MATERIAL SHOULD BE ROLLED OR COMPACTED OVER THE FILL PRIOR TO INSTALLATION OF THE VAPOR BARRIER/RETARDER TO REDUCE THE POSSIBILITY OF PUNCTURE. VAPOR RETARDER SHOULD BE OVERLAPPED 8 IN. AND TAPED AT THE JOINTS AND CAREFULLY FITTED AROUND SERVICE OPENINGS.

3.00 REINFORCED CONCRETE

- 3.01 ALL CONCRETE WORK SHALL CONFORM TO ACI 301-10, SPECIFICATIONS FOR STRUCTURAL CONCRETE FOR BUILDINGS. DESIGN IS BASED ON ACI 318-11, BUILDING CODE REQUIREMENTS FOR REINFORCED CONCRETE. DETAIL CONCRETE REINFORCEMENT AND ACCESSORIES IN ACCORDANCE WITH ACI 315, DETAILING MANUAL. DETAIL ALL CONCRETE WALLS AND BEAMS ON THE SHOP DRAWINGS IN ELEVATION UNLESS SPECIFICALLY APPROVED OTHERWISE. SUBMIT SHOP DRAWINGS FOR APPROVAL, SHOWING ALL FABRICATION DIMENSIONS AND LOCATIONS FOR PLACING REINFORCING STEEL AND ACCESSORIES. DO NOT BEGIN FABRICATION UNTIL SHOP DRAWINGS ARE COMPLETED AND REVIEWED.
- 3.02 UNLESS NOTED OTHERWISE, ALL CONCRETE SHALL BE NORMAL WEIGHT AND HAVE THE FOLLOWING MINIMUM 28 DAY COMPRESSIVE STRENGTHS:
 - A. FOUNDATIONS 3000 PSI
 - B. SLAB-ON-GRADE 3000 PSI
 ALL CONCRETE SHALL HAVE ENTRAINED AIR, U.N.O. CONCRETE MAY CONTAIN A PROPERLY DESIGNED SUPERPLASTICIZER FOR WORKABILITY.
- 3.03 REINFORCING STEEL SHALL CONFORM TO ASTM A615, GRADE 60 UNLESS NOTED OTHERWISE.
- 3.04 THE PROPOSED MATERIALS AND MIX DESIGN SHALL BE FULLY DOCUMENTED AND REVIEWED BY THE OWNER'S TESTING LABORATORY. RESPONSIBILITY FOR OBTAINING THE REQUIRED DESIGN STRENGTH IS THE CONTRACTOR'S.
- 3.05 USE OF CALCIUM CHLORIDE, CHLORIDE IONS, OR OTHER SALTS IN CONCRETE IS NOT PERMITTED.
- 3.06 HORIZONTAL CONSTRUCTION JOINTS ARE NOT PERMITTED. VERTICAL CONTROL JOINTS ARE NOT PERMITTED OTHER THAN IN SLABS-ON-GRADE AS SHOWN AND DETAILED.
- 3.07 CHAMFER OR ROUND ALL EXPOSED CORNERS A MINIMUM OF 3/4".
- 3.08 TIE ALL REINFORCING STEEL AND EMBEDMENTS SECURELY IN PLACE PRIOR TO PLACING CONCRETE. PROVIDE SUFFICIENT SUPPORTS TO MAINTAIN THE POSITION OF REINFORCEMENT WITHIN SPECIFIED TOLERANCE DURING ALL CONSTRUCTION ACTIVITIES. "STICKING" DOWELS INTO WET CONCRETE IS NOT PERMITTED.
- 3.09 PROVIDE CONTINUOUS REINFORCEMENT WHEREVER POSSIBLE; SPLICE ONLY AS SHOWN OR APPROVED; STAGGER SPLICE WHERE POSSIBLE; USE FULL TENSION SPLICE (CLASS "B") UNLESS NOTED OTHERWISE. DOWELS SHALL MATCH THE SIZE AND SPACING OF THE SPECIFIED REINFORCEMENT AND SHALL BE LAPPED WITH FULL TENSION SPLICES (CLASS "B") UNLESS NOTED OTHERWISE. TERMINATE BARS WITH STANDARD HOOKS.
- 3.10 REINFORCING STEEL SHALL HAVE THE FOLLOWING CONCRETE COVER UNLESS NOTED OTHERWISE (PER ACI 318-05 PAR.7.7.1):
 - A. CONCRETE AGAINST EARTH (NOT FORMED): 3"
 - B. FORMED CONCRETE EXPOSED TO THE EARTH OR WEATHER:
 - 1. #6 THROUGH #18 BARS: 2"
 - 2. #5 BARS AND SMALLER: 1-1/2"
- 3.11 DO NOT WELD OR TACK WELD REINFORCING STEEL UNLESS APPROVED OR DIRECTED BY THE STRUCTURAL ENGINEER.
- 3.12 ALL REINFORCING STEEL PLACEMENTS SHALL BE REVIEWED BY A REGISTERED STRUCTURAL ENGINEER, OR BY A REPRESENTATIVE RESPONSIBLE TO HIM. (RE: ACI 318 PAR. 1.3.1)
- 3.13 FOR ADDITIONAL CONCRETE SITE PADS SEE THE CIVIL, ARCHITECTURAL, MECHANICAL OR ELECTRICAL DRAWINGS.

4.00 PRE-ENGINEERED METAL BUILDINGS

- 4.01 BUILDING SHALL BE CONSTRUCTED IN ACCORDANCE WITH METAL BUILDING MANUFACTURER'S ASSOCIATION (MBMA) CRITERIA.
- 4.02 BUILDING SHALL BE DESIGNED FOR THE WIND AND SUPERIMPOSED GRAVITY LOADS AS SHOWN IN SECTION 1.00 OF THESE NOTES AS WELL AS THE ADDITIONAL LOADS:
 - A. BUILDING SELF-WEIGHT
 - B. COLLATERAL LOAD = 5 PSF
 - C. REDUCIBLE ROOF LIVE LOAD PER CODE
- 4.03 THE FOUNDATIONS HAVE BEEN DESIGNED BASED ON THE ASSUMPTION THAT THE RIGID FRAMES ARE PINNED AT THE BASE. THE FINAL FOUNDATION FORCES/REACTIONS SHALL BE SUBMITTED TO THE ENGINEER OF RECORD FOR REVIEW PRIOR TO FABRICATION OF THE PEMB. THE PURPOSE OF THIS REVIEW IS TO GIVE THE ENGINEER OF RECORD OPPORTUNITY TO VERIFY THE FOUNDATION DESIGN. REVISIONS TO THE FOUNDATION DESIGN MAY BE NECESSARY PENDING THE REVIEW OF THIS SUBMITTAL.
- 4.04 DRIFT CRITERIA: H/100
- 4.05 GIRT DEFLECTION CRITERIA FOR METAL PANELS: L/120
- 4.06 PROVIDE SUPPORT FOR WALLS BY OTHERS AT EAVES AND DESIGN FRAMES FOR WIND LOAD FROM WALLS BY OTHERS.
- 4.07 SUPPORT FOR CRANES AND MONORAILS BY OTHERS. ALL COLUMNS ARE ASSUMED TO BE PINNED AT THE BASE. HORIZONTAL CRANE AND MONORAIL STABILITY IS TO BE PROVIDED BY THE METAL BUILDING MANUFACTURER.

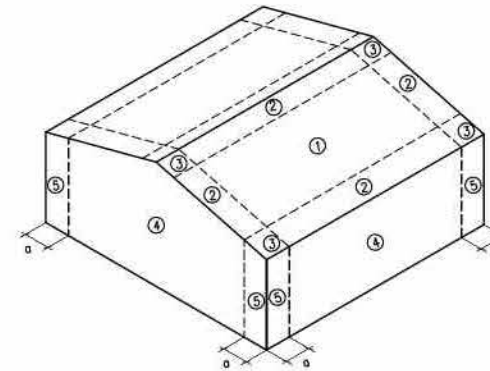

WIND LOAD DETERMINATION ASSUMPTIONS					
WIND VELOCITY (MPH)	EXPOSURE CATEGORY	MEAN ROOF HEIGHT (FT.)	ROOF SLOPE	RISK CATEGORY	ENCLOSURE CATEGORY
150	C	15	2 ON 12	IV	ENCLOSED

ULTIMATE DESIGN WIND PRESSURES FOR COMPONENTS AND CLADDING (PSF)												
EFF. AREA (SQ. FT)	ROOF ZONE 1		ROOF ZONE 2		ROOF ZONE 3		WALL ZONE 4		WALL ZONE 5			
				O-HANG		O-HANG						
≤ 10	28.3	-44.9	28.3	-78.1	-91.4	28.3	-78.1	-91.4	44.9	-48.6	44.9	-59.8
20	25.8	-43.6	25.8	-71.9	-91.4	25.8	-71.9	-91.4	42.9	-46.6	42.9	-55.9
50	22.5	-42.0	22.5	-63.6	-91.4	22.5	-63.6	-91.4	40.3	-44.0	40.3	-50.6
≥ 100	19.9	-40.7	19.9	-57.4	-91.4	19.9	-57.4	-91.4	38.3	-42.0	38.3	-46.6

NOTES:
 1. FOR EFFECTIVE AREAS BETWEEN THOSE GIVEN ABOVE THE LOAD MAY BE INTERPOLATED, OTHERWISE USE THE LOAD ASSOCIATED WITH THE LOWER EFFECTIVE AREA.
 2. THE EDGE STRIP, 'd', = 3 FT.
 3. PRESSURES SHALL BE APPLIED IN ACCORDANCE WITH THE FIGURE SHOWN ON THIS SHEET.

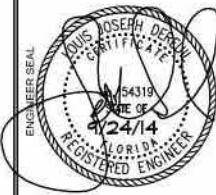

NO. DESIGNED BY:	MLM
DATE:	MLM
DRAWN BY:	MLM
CHECKED BY:	LJD
APPROVED BY:	LJD

GENERAL NOTES
OKALOOSA COUNTY
EAST COUNTY PUMP STATION PROJECT



FILE	SEE LEFT
VERIFY SCALE	
BAR IS ONE INCH ON ORIGINAL DRAWING	
DATE	SEPT. 24, 2014
PROJ.	100100.70
DWG.	S1.0

Z:\PROJECT FILES\100100.70 OCWS TO 70 - EAST COUNTY PUMP STATION PROJECT_300 FINAL DRAWINGS\02 PROCESS MECH\M- MECHANICAL.DWG
 REUSE OF DOCUMENTS: THIS DOCUMENT AND THE IDEAS AND DESIGNS INCORPORATED HEREIN, AS AN INSTRUMENT OF PROFESSIONAL SERVICE, IS THE PROPERTY OF CONSTANTINE ENGINEERING. HOWEVER, THIS SHALL NOT PROHIBIT THE REUSE OF THIS DOCUMENT BY THE CLIENT AS PROVIDED FOR BY THE CONTRACT.

10/8/2014 10:03 AM

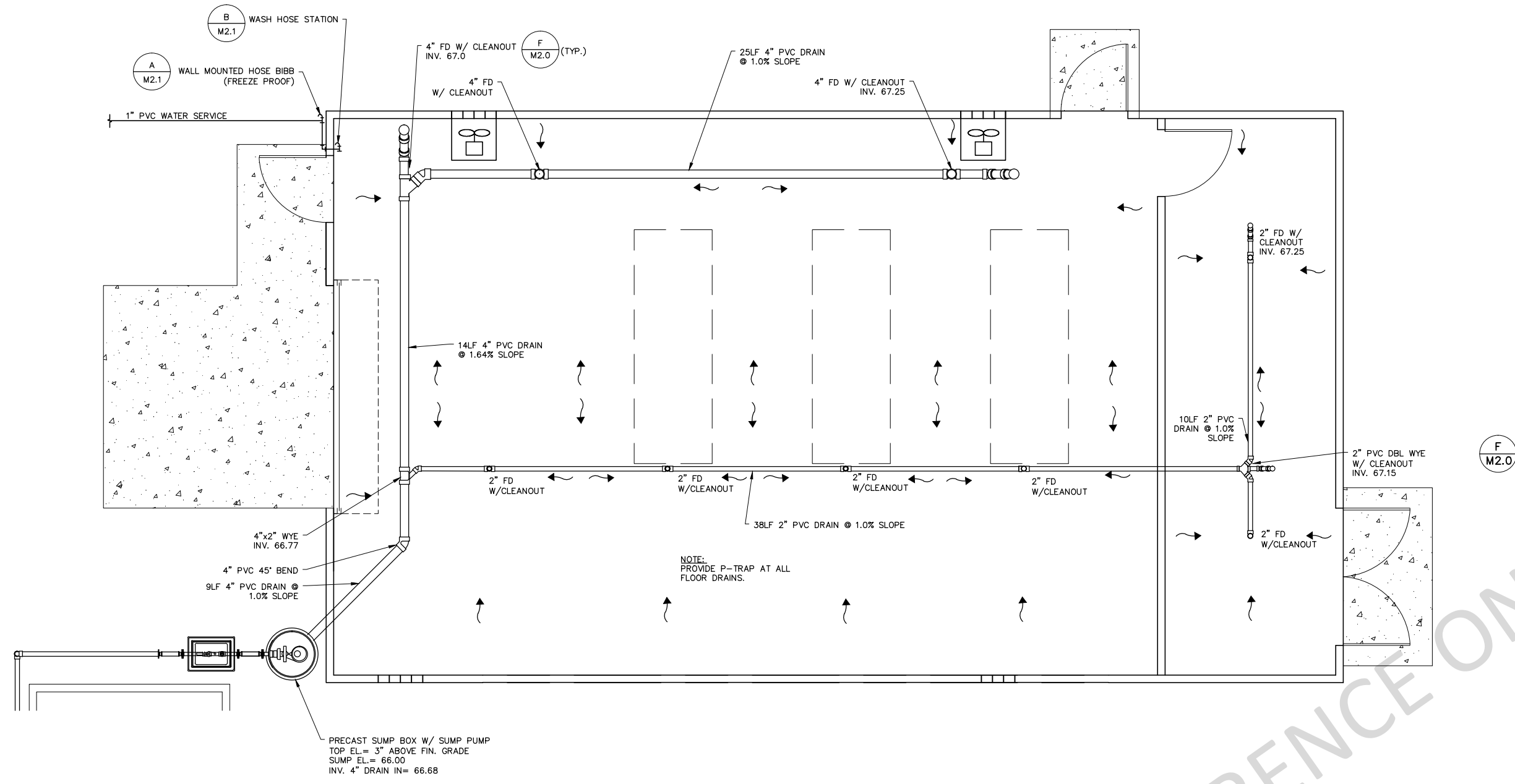

NOTE:
 PROVIDE P-TRAP AT ALL
 FLOOR DRAINS.

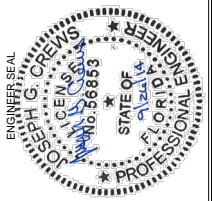
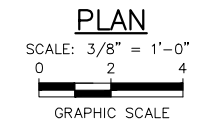

NO.	DATE	DESIGNED BY:	DRAWN BY:	REVISION	CHECKED BY:	APPROVED BY:
		J. CREWS	R. MCLEMORE		J. CREWS	J. KIZER

MECHANICAL PIPING PLAN

OKALOOSA COUNTY
 EAST COUNTY RE-PUMP METAL BUILDING



FILE	SEE LEFT
VERIFY SCALE	
DATE	SEPT., 2014
PROJ.	100100.70
DWG.	M1.2

REFERENCE ONLY